

Tumble dryer

T4300LE

Features and benefits

- Heat pump Tumble Dryer
- Low energy consumption: 0.22 kWh/kg load
- Exhaust duct not needed
- Reversing drum
- Residual moisture control – RMC
- Large door opening for easy loading and unloading
- Anti-wrinkle function
- Built-in service program

Main options

- Stainless steel drum



Main specifications		T4300LE	
Rated capacity, filling factor 1:22/1:30/1:50	kg	13.6/10/6	
Drum volume	litre	300	
Drum diameter	mm	760	
Heat pump effect	kW	3	
Consumption data*			
Status at start		Warm	Cold
Drying time	min	62/46/31	73/54/38
Energy consumption	kWh	2.76/2.01/1.36	3.01/2.24/1.54
Energy/Water evaporation	kWh/l	0.40/0.40/0.44	0.44/0.44/0.50
Energy/Load of linen	kWh/kg	0.20/0.20/0.23	0.22/0.22/0.26
* At rated capacity 100% cotton load at 50% initial moisture dried to 0%.			

Certified in accordance with ISO 9001 and ISO 14001 and approved IP X4.

Electrical connections		T4300LE	
Heating Voltage			
400-415V 3NAC 50 Hz	kW(A)	4 (10)	
230-240V 3AC 50 Hz	kW(A)	4 (16)	
Condense connection			
Drain diameter	∅	25	
Sound levels			
Airborne sound level	dB(A)	<70	
Heat emission			
% of installed power, max		15	
Shipping data			
	Cabinet, net, kg	120	
	Heat pump unit, net, kg	150	
	total net, kg	270	
Dimensions in mm			
A	Width	790	
B	Depth	1284	
C	Height	1663	
D		935	
E		740	
F		2024	
G		100	
H		270	
J		895	
1	Door opening ∅ 580 mm	3	Electrical connection
2	Control panel	4	Condense outlet

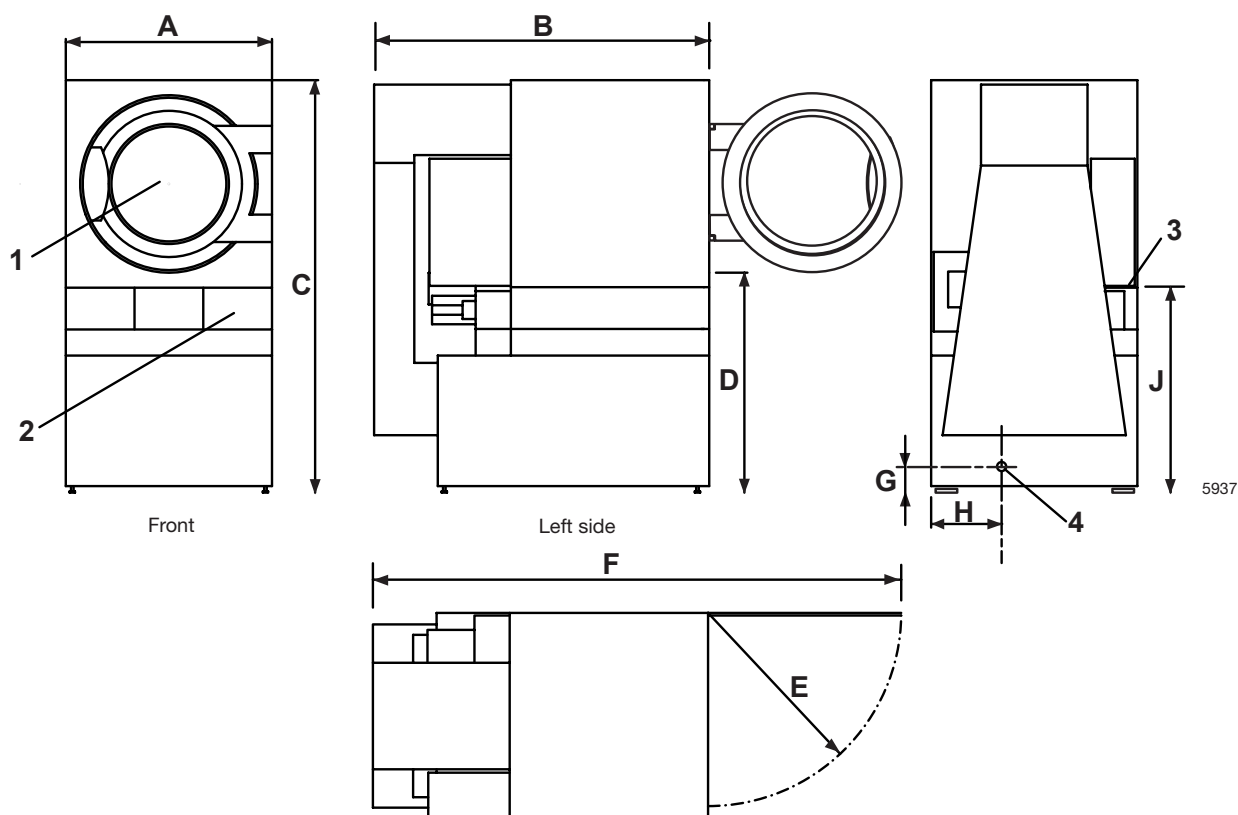

 **Electrolux**

www.electrolux.com/professional

Share more of our thinking at www.electrolux.com