

Washer extractor

W4300H

Features and benefits

- High extraction force for efficient dewatering
- Available with two types of program controls:
 - Compass Control® with:**
 - Large display and one dial for easy program selection
 - Language selection
 - Two Quick Start buttons for frequently used wash programs
 - Wash program packages optimized on *Economy, Performance and Time*
 - Clarus Control® with:**
 - Fully programmable microprocessor
 - All relevant wash parameters can be programmed
 - Programming from key pad or downloading via memory card
- AWS – Automatic Weighing System with Compass Control – determine the wash load and adopt the water intake accordingly. Savings on water and energy if machine is not fully loaded
- Extremely low water and energy consumption – see table below
- Four compartment soap box for manual dosing of powder or liquid detergent
- Stainless steel front panel and grey side panels
- Large door opening for easy loading/unloading
- Low noise level, for pleasant working environment
- SuperBalance™ guarantees the correct extraction force



Clarus Control

Main options

- Automatic liquid detergent supply (optional I/O board for Compass Control)
- IWS – Integrated Weighing System™ – actual load will be shown in the display (Clarus Control only)
- Stainless steel side panel (Clarus Control only)
- Connection to payment system or coin meter (Compass Control only)
- Dual drain valves for water re-use (Clarus Control only)



Compass Control

| Main specifications | | | | W4300H | |
|---|-------------|-------|--|-----------|--------|
| Max. capacity | | kg/lb | | 33/70 | |
| Drum, volume | | litre | | 302 | |
| | diameter | ø mm | | 795 | |
| Extraction | | rpm | | 820 | |
| G-factor | | | | 300 | |
| Heating alternatives, 230/400V | electricity | kW | | 19.4 | |
| | steam | | | x | |
| | non-heated | | | x | |
| Consumption data "Normal 60°C" * (3G01) | | | | EI | Steam |
| Total time | | min | | 48 | ** |
| Water consumption (cold/hot) | | litre | | 202/52 | 202/52 |
| Energy consumption (motor/heating)* | | kWh | | 0.55/1.35 | 0.55 |
| Steam consumption | | kg | | - | 2 |
| * Water temperature 15°C cold water and 65°C hot water. | | | | | |
| ** Depending on steam pressure. | | | | | |

Certified in accordance with ISO 9001 and ISO 14001 and approved IP 24D.

| Electrical connections* | | W4300H | |
|------------------------------------|------------------------|-----------|---------------------------|
| Heating | Voltage | | |
| EI. | 230V 3 AC 50 Hz | kW(A) | 19.4(63) |
| | 208-240V 3AC 60 Hz | kW(A) | 19.4(63) |
| | 400-415V 3N AC 50 Hz | kW(A) | 19.4(35) |
| Steam | 230V 1AC 60 Hz | kW(A) | 2.1(10) |
| or | 208-240V 1AC 60 Hz | kW(A) | 2.1(10) |
| non-heated | 230V 1AC 50 Hz | kW(A) | 2.1(10) |
| Water and steam connection | | | |
| Water valves | DN | 20 | |
| Water pressure | kPa | 150-400 | |
| Capacity at 300 kPa | l/min | 60 | |
| Drain valve | Ømm | 75 | |
| Draining capacity | l/min | 150 | |
| Steam valve | DN | 15 | |
| Steam pressure | kPa | 300-600 | |
| Liquid detergent supplies | | 5 | |
| Floor requirements | | | |
| Frequency of the dynamic force | Hz | 13.7 | |
| Max floor load at extraction | kN | 5.5 ± 1.3 | |
| Sound levels | | | |
| Sound pressure level** | dB(A) | 76 | |
| Sound power level (IEC 60704-2-4) | dB(A) | 83 | |
| Heat emission | | | |
| % of installed power, max | | 5 | |
| Shipping data | | | |
| Weight | net, kg | 509 | |
| | crated, kg | 528 | |
| Shipping volume | m ³ | 2.1 | |
| Accessories | | | |
| Steel base frame | | x | |
| Water re-use tank (Clarus Control) | | x | |
| Hose kits for water or steam | | x | |
| Dimensions in mm | | | |
| A | Width | 1020 | |
| B | Depth | 1060 | |
| C | Height | 1445 | |
| D | | 500 | |
| E | | 1135 | |
| F | | 1155 | |
| G | | 100 | |
| H | | 1360 | |
| I | | 215 | |
| K | | 1320 | |
| L | | 300 | |
| M | | 380 | |
| N | | 100 | |
| O | | 360 | |
| P | | 330 | |
| 1 | Electrical connections | 6 | Liquid supply connections |
| 2 | Cold water | 7 | Control panel |
| 3 | Hot water | 8 | Soap box |
| 4 | Steam connection | 9 | Door opening ø435 |
| 5 | Drain | | |

* Other voltages available, see installation manual.

** Approx. value at operators position in a mid-size laundry room.

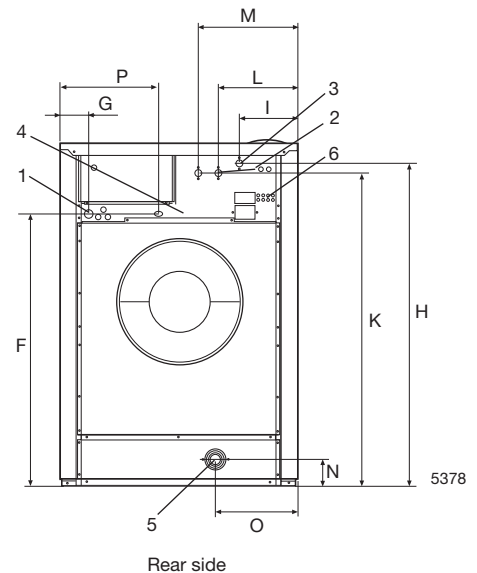
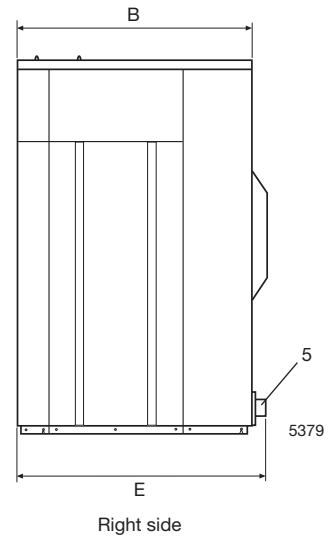
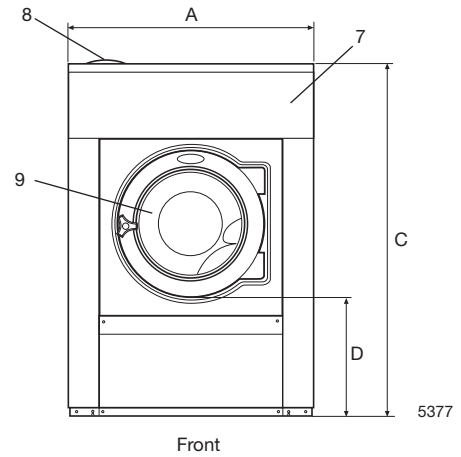

 **Electrolux**

www.electrolux.com/professional

Share more of our thinking at www.electrolux.com

Art. No. 438901941/01 07.04
We reserve the right to alter specifications without notice.