

Washer extractor

W4330N

Features and benefits

- Solid mount construction with robust frame in galvanized steel
- Extremely low water and energy consumption – see table below
- Available with two types of program controls:
 - Classic Control with:**
 - Program timer available in two versions; either with 5 wash programs (laundrettes) or 10 wash programs (other laundries)
 - Compass Control® with:**
 - Large display and one dial for easy program selection
 - Language selection
 - Two Quick Start buttons for frequently used wash programs
 - Wash program packages optimized on *Economy*, *Performance* and *Time*
- Four compartment soap box for manual dosing of powder or liquid detergent
- Large door opening for easy loading/unloading
- Stainless and galvanized steel in all vital parts for high degree of rust protection



Compass Control



Classic Control

Main options

- Automatic liquid detergent supply (optional I/O board for Compass Control)
- Stainless steel front panel
- Connection of coin meter

Main specifications				W4330N	
Max. capacity		kg/lb		35/75	
Drum, volume diameter		litre		330	
		ø mm		795	
Extraction		rpm		427	
G-factor				81	
Heating alternatives, 230/400V	electricity	kW		19.2	
	steam			x	
	non-heated			x	
Consumption data "Normal 60°C" * (3G01)				EI	Steam
Total time		min		50	**
Water consumption (cold/hot)		litre		234/62	234/62
Energy consumption (motor/heating)*		kWh		0.4/1.6	0.4
Steam consumption		kg		–	2.4
* Water temperature 15°C cold water and 65°C hot water.					
** Depending on steam pressure.					

Certified in accordance with ISO 9001 and ISO 14001 and approved IP 24D.

Electrical connections*		W4330N	
Heating Voltage			
El.	230V 3 AC 50 Hz	kW(A)	20(63)
	240V 3AC 60 Hz	kW(A)	20.7(63)
	400V 3N AC 50 Hz	kW(A)	19.2(35)
Steam	230V 3AC 60 Hz	kW(A)	1.9(10)
or	240V 3AC 60 Hz	kW(A)	1.9(10)
non-heated	400V 3N AC 50Hz	kW(A)	1.7(10)
Water and steam connection			
Water valves	DN		20
Water pressure	kPa		150-400
Capacity at 300 kPa	l/min		60
Drain valve	Ømm		75
Draining capacity	l/min		150
Steam valve	DN		15
Steam pressure	kPa		300-600
Liquid detergent supplies			5
Floor requirements			
Frequency of the dynamic force	Hz		7.5
Max floor load at extraction	kN		3.8 ± 6.0
Sound levels			
Sound pressure level**	dB(A)		70
Sound power level (IEC 60704-2-4)	dB(A)		76
Heat emission			
% of installed power, max			5
Shipping data			
	net, kg		330
	crated, kg		350
Shipping volume	m ³		1.82
Accessories			
Hose kits for water or steam			x
Dimensions in mm			
A	Width		910
B	Depth		1040
C	Height		1445
D			500
E			1075
F			1155
G			45
H			1365
I			160
K			1325
L			245
M			1155
N			280
O			325
P			100
R			210
1	Electrical connections	6	Liquid supply connections
2	Cold water	7	Control panel
3	Hot water	8	Soap box
4	Steam connection	9	Connections for water re-use
5	Drain	10	Door opening ø435

Front and side panels in light grey with "Blue Wave" on front panel (RAL 260 70 05, 250 60 30)

* Other voltages available, see installation manual

** Approx. value at operators position in a mid-size laundry room

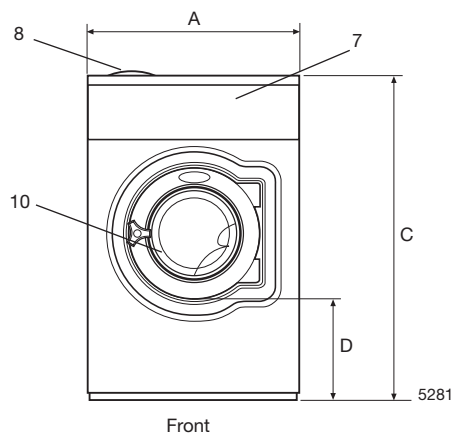

Front

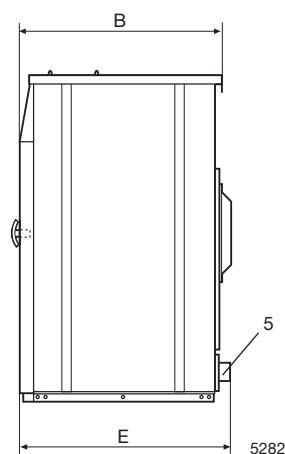

Right side

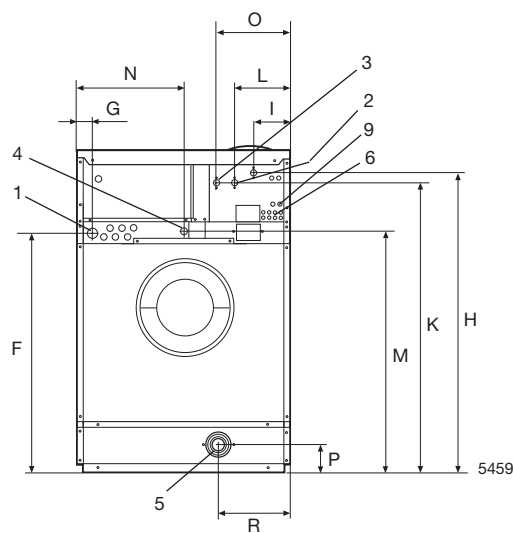

Rear side

 **Electrolux**

www.electrolux.com/professional

Share more of our thinking at www.electrolux.com

Art. No. 438901821/01 07.04
We reserve the right to alter specifications without notice.